



EM111-RTU-2P

Manual

## Revision History

Version	Date	Change
0	2021.3.9	First edition

# Contents

General.....	4
Copyright.....	4
Trademarks.....	4
Disclaimer.....	4
Meaning of the symbols.....	4
Application notes.....	5
About these operating instructions.....	6
Incoming goods inspection.....	6
Scope of delivery.....	6
Product description.....	7
Intended use.....	7
Specifications.....	8
Operating concept.....	10
EM configuration tools.....	11
Connection options.....	11
Assembly.....	12
Installation location.....	12
Power supply.....	12
Voltage and current measurement inputs.....	13
Direction of the current.....	14
RS485 interface.....	14
Terminating resistors.....	15
Shielding.....	15
Cable type.....	16
Maximum cable length.....	16
Bus structure.....	16
Pulse Output.....	18
Examples of electrical connections.....	19
Configuration and display.....	20
Self-check after power on.....	20
Button functions.....	20
Overview of measured value displays.....	21
Set-up Mode.....	22
Modbus Communication Protocol.....	23
Input Registers, Function code 04.....	23
Holding Register, Function code 03/10.....	24
Dimensional drawings.....	25
Connecting example.....	26

# General

This manual applies to the products:  
7760051001 Energy Meter EM111-RTU-2P

## Copyright

This manual is subject to the laws of copyright protection and may not be mechanically or electronically photocopied, reprinted, reproduced or otherwise reproduced or published in part or as a whole, without the legally binding, written consent of

Weidmüller Interface GmbH & Co. KG  
Klingenbergstraße 26  
32758 Detmold Germany

## Trademarks



All trademarks and the rights resulting from them remain the property of the trademark holder of these rights.

## Disclaimer

Weidmüller assumes no responsibility for errors or omissions in this manual and assumes no obligation to keep the contents of this manual up to date.

## Meaning of the symbols

The following pictograms are used in this manual:

	<b>Dangerous voltage!</b> Risk of death or serious injury. Disconnect the power before working on the system and device.
	<b>Attention!</b> Please refer to the documentation. This symbol will warn you of possible dangers that could occur during assembly, commissioning and operation.
	Note!

## Application notes

Please read these operating instructions and all other publications that must be consulted in order to work with this product (particularly for installation, operation or maintenance).

Please observe all safety regulations and warnings. Non-compliance with the instructions can lead to personal injury and/or damage to the product.





Any unauthorized alteration or use of this device which exceeds the specified mechanical, electrical or other operational limits can cause personal injury and/or damage to the product.

Any such unauthorized alterations are grounds for "abuse" and/ or "negligence" in terms of the product's guarantee and thus excludes the warranty for covering any possible resulting damages.

This device must only be operated and maintained by qualified personnel.

Qualified personnel are persons who, due to their respective training and experience, are able to recognize risks and avoid potential hazards that can be caused by operation or maintenance of the device.

When using the device, the legal and safety regulations required for the respective application must also be observed.

	Safety is no longer guaranteed and the device may be dangerous if the device is not operated according to the operating instructions.		Only screw terminals with the same number of poles and the same type may be plugged together.
	All signals connected with the device's SELV circuit must also conform with the SELV provisions.		Conductors consisting of single wires must be provided with ferrules.

## About these operating instructions

These operating instructions are part of the product.

- Read the operating instructions prior to using the device.
- Keep the operating instructions at hand throughout the entire service life of the product and keep ready for referencing.
- Hand over the operating instructions to each subsequent owner or user of the product.

## Incoming goods inspection

The proper and safe operation of this device requires appropriate transport, proper storage, installation and assembly as well as careful operation and maintenance. When it is assumed that safe operation is no longer possible, the device must immediately be taken out of operation and secured against accidental start-up. Unpacking and packing must be carried out with the usual care, without the use of force and only with the use of suitable tools. The devices must be visually inspected for proper mechanical condition. It can be assumed that safe operation is no longer possible if the device, e.g.

- shows visible damage;
- does not work despite intact power supply;
- and was exposed to unfavorable conditions (e.g. storage outside of the permissible climatic limits without adaptation to the ambient climate, condensation, etc.) or transport stresses (e.g. falling from a great height even without exterior visible damage, etc.) for prolonged periods;
- Please check that the is complete before you begin with installation of the device.

## Scope of delivery

Quantity	Designation
1	Energy Meter 111
1	Quick guide

# Product description

## Intended use

The Energy Meter 111 measures and displays the characteristics of 1P2W's applications. The unit provides voltage, current, power, frequency, power-factor, and energy etc.

The Energy Meter 111 is permanently installed in control cabinets or small distribution boards. It can be installed in any position.

Measurement voltages and measurement currents must originate from the same grid.

The measurement results can be displayed and can be read and processed over the RS485 interface.

The Energy Meter 111 designed for mounting in low voltage distributions, containing overvoltage in measurement category II .

Energy Meter EM111-RTU-2P supports max. 45A direct connection, saves the cost and avoid the trouble to connect external CTs, giving the unit a cost-effective and easy operation.

EM111 series have one RS485 remote communication port.

## Specifications

Electrical characteristics		
Type of measurement	Single phase AC	
Measurement accuracy	Voltage	0.5%
	Current	0.5%
	Frequency	0.2%
	Power Factor	±0.01
	Active Power	1%
	Reactive Power	2%
	Apparent Power	2%
	Active Energy	IEC62053-21 Class 1/EN50470-3 Class B
	Reactive Energy	2%
Input-Voltage	Un	230 V L-N
	Measured Voltage with Over-range and Crest Factor	176-276V AC
	Frequency Range	50/60Hz
Input- Current	Base Current	5A
	Max. Current	45A
	Min. Current	0.25A
	Over current withstand	30 x I <sub>max</sub> 0.01s
	Frequency Range	50/60Hz
Auxiliary Power Supply	Operating Range	Self powered
	Power Consumption	<2W/10VA
	Frequency	50/60 Hz



Digital output	Pulse output 1	0.001/0.01/0.1/1kWh/kVarh(configurable)
	Pulse output 2	1000imp/kWh(non-configurable)
<b>Mechanical Characteristics</b>		
Weight	90g	
IP Degree of Protection (IEC 60529)	IP51 for front display; IP20 for others	
Dimensions (WxHxD)	90x17.5x62mm	
Material of meter case	UL 94-V0	
<b>Environmental Characteristics</b>		
Operating Temperature	-25 ~ 55°C	
Storage Temperature	-40 ~ 70°C	
Humidity Rating	≤90% (non-condensing)	
Pollution Degree	2	
Altitude	<2000m	
<b>EMC</b>		
Electrostatic Discharge	IEC 61000-4-2	
Immunity to Radiated Fields	IEC 61000-4-3	
Immunity to Fast Transients	IEC 61000-4-4	
Immunity to Impulse Waves	IEC 61000-4-5	
Conducted Immunity	IEC 61000-4-6	
Immunity to Magnetic Fields	IEC 61000-4-8	
Immunity to Voltage Dips	IEC 61000-4-11	
Radiated Emissions	CISPR 11 Class B	
Conducted Emissions	CISPR 11 Class B	
Harmonics	IEC 61000-3-2	
<b>Safety</b>		
Measurement Category	IEC61010-1 CAT II	
Over voltage Category	CAT II	
<b>Communications</b>		
Interface standard and protocol	RS485 and MODBUS RTU	
Communication address	1~247	
Transmission mode	Half duplex	
Transmission distance	1000m Maximum	

Transmission speed	2400bps~38400bps
Parity	None (default), Odd, Even
Stop bits	1 or 2
Connection capacity of the terminals (voltage measurement)	
Single-wire, multi-wire, finely stranded conductor	2.5-10mm <sup>2</sup>
Pin terminals,ferrules	2.5-10mm <sup>2</sup>
Tightening torque	1.2-1.5 Nm
Stripping length	8mm
Connection capacity of the terminals (RS485 and output)	
Single-wire, multi-wire, finely stranded conductor	0.5-1.5mm <sup>2</sup>
Pin terminals,ferrules	0.5-1.5mm <sup>2</sup>
Tightening torque	0.2-0.25 Nm
Stripping length	7mm

## Operating concept

There are several ways to program the Energy Meter 111 and retrieve measured values.

- Directly on the device using the button(only read).
- Via the programming software of the EM configuration tools.
- Via the RS485 interface with the Modbus protocol. Data can be changed and retrieved with the help of the Modbus address list (stored on the accompanying data carrier).

These operating instructions only describe the operation of the Energy Meter 111 using the button. The programming software of the EM configuration tools has its own "on- line help".

## EM configuration tools

The Energy Meter 111 can be programmed and read with the EM configuration tools software. For this, a PC must be connected to the RS485 interface of the Energy Meter 111 via an RS485 Modbus to TCP/IP gateway.

## Connection options

Connection of Energy Meter 111 to PC via an EM220-RTU-4DI2DO-GW as a gateway:

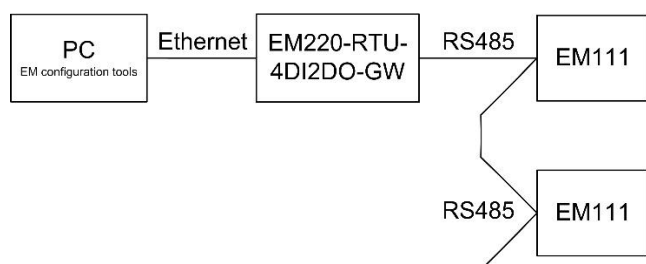

# Assembly

## Installation location

The Energy Meter 111 can be installed in control cabinets or in small distribution boards according to DIN 43880. It is mounted on a 35 mm mounting rail according to DIN EN 60715. It can be installed in any position.

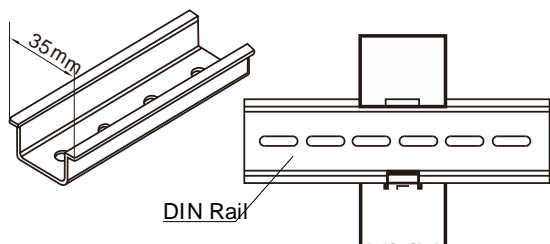

Fig.: Energy Meter 111 on mounting rail according to DIN EN 60715

## Power supply

EM111 takes power from the voltage measurement port without additional power supply, to ensure that the voltage of measurement port complies with the information on the nameplate!



- The supply voltage must be connected through a fuse according to the technical data.
- In building installations, the supply voltage must be provided with a disconnect switch or circuit breaker.
- The disconnect switch must be attached near the device and must be easily accessible by the user.
- The switch must be labelled as a separator for this device.
- Voltages that exceed the permissible voltage range can destroy the device.

## Voltage and current measurement inputs

When connecting the voltage measurement, the following must be observed:

### Isolation device

- A suitable circuit breaker must be fitted to disconnect and deenergize the Energy Meter 111.
- The circuit breaker must be placed in the vicinity of the Energy Meter 111, be marked for the user and easily accessible.
- The circuit breaker must be UL/IEC certified.

### Overcurrent protection device

- An overcurrent protection device must be used for line protection.
- For line protection, we recommend an overcurrent protection device as per the technical specifications.
- The overcurrent protection device must be suitable for the line cross section used.
- The overcurrent protection device must be UL/IEC certified.
- A circuit breaker can be used as an isolating and line protection device. The circuit breaker must be UL/IEC certified.

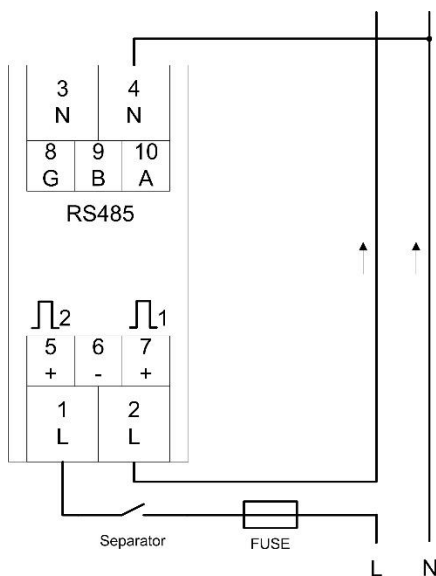





Fig.: Connection example for the voltage and current measurement

	<p><b>Attention!</b> The Energy Meter 111 is not suitable for the measurement of DC voltages.</p>
	<p><b>Attention!</b> The voltage measurement inputs on the Energy Meter 111 are dangerous to touch!</p>
	<p>The attached screw terminal has to be fixed sufficiently with the screws on the device!</p>

## Direction of the current

Please wire in strict accordance with the current direction. If the connection is reversed, rewire it!

## RS485 interface

The RS485 interface is designed with the Energy Meter 111 as a 3-pole contact and communicates via the Modbus RTU protocol (please see the registers address list of Modbus RTU protocol ).

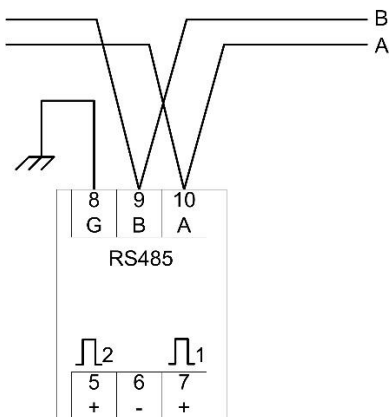

Fig.: RS485 interface, 3-pole contact

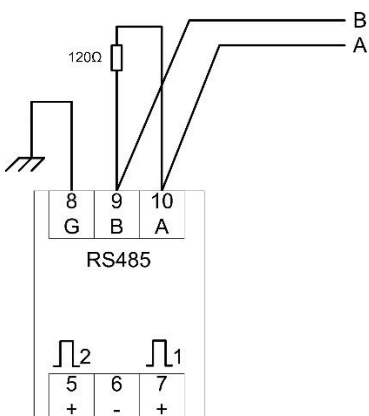
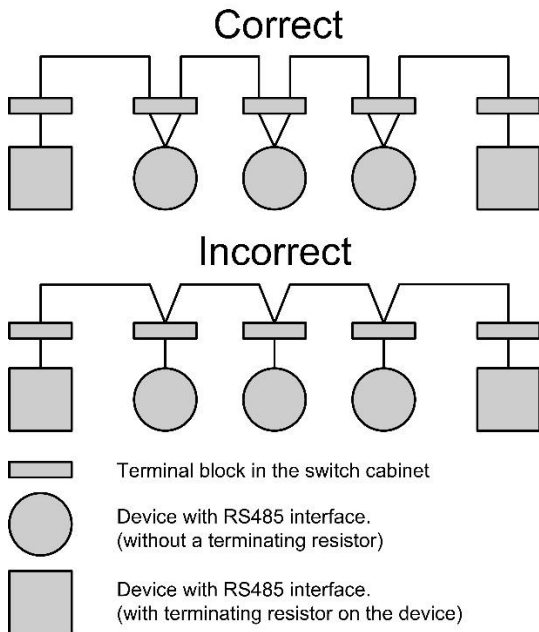

Fig.: RS485 interface, 3-pole contact with terminating resistor

## Terminating resistors

The cable should be terminated with resistors (120 ohm 1/4 W) at the beginning and end of a segment if the communication distance larger than 300m.

The Energy Meter 111 has no terminating resistors.



## Shielding

A twisted and shielded cable must be provided for connections via the RS485 interface.

- Ground the shields of all cables that run into the cabinet at the cabinet entry.
- Connect the shield so it has a large contact area and conductively with a low-noise earth.
- Mechanically trap the cable above the earthing clamp in order to avoid damage from cable movement.
- Use the appropriate cable inlets, e.g. PG screw joints, to insert the cable into the switch cabinet.

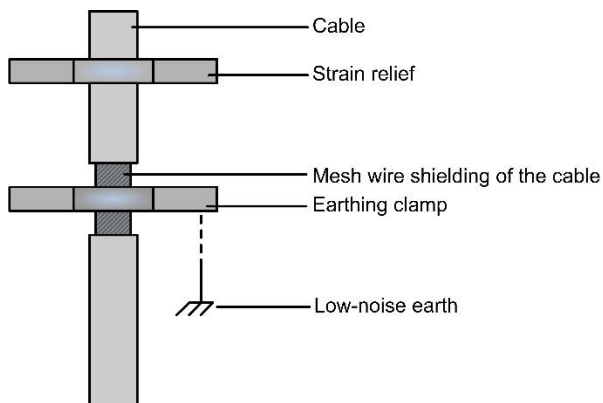



Fig.: Shielding design for cabinet entry

## Cable type

The cable used must be suitable for an ambient temperature of at least 80 °C.

	For the wiring of the Modbus connection, CAT cables are not suitable. Please use the recommended cables.
---	--

## Maximum cable length

Max 1000m.

## Bus structure

- All devices are connected in a bus structure (line) and each device has its own address within the bus (also see programming parameters).
- Up to 32 stations can be interconnected in one segment.
- The cable is terminated with resistors (bus termination, 120 ohm 1/4 W) at the beginning and end of a segment.
- If there are more than 32 stations, repeaters (line amplifiers) must be used in order to connect the individual segments.
- Devices with activated bus termination must be supplied with power.
- It is recommended to set the master at the end of a segment.
- The bus is inoperative if the master is replaced with an activated bus termination.
- The bus can become unstable if the slave is replaced with an activated bus termination or is dead.
- Devices that are not involved in the bus termination can be exchanged without making the bus unstable.

The shield has to be installed continuously and needs to be broadly and well conducting connected to an external low voltage (or potential) ground at the end.

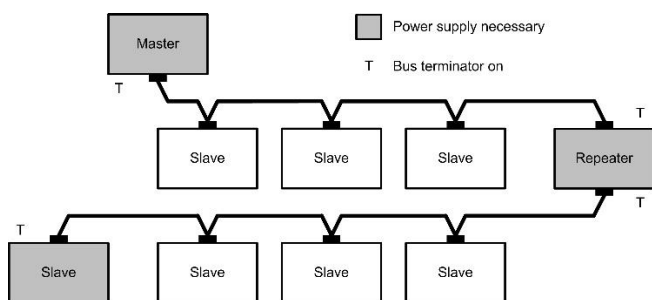

Fig.: Diagram of RS485 bus structure





## Pulse Output

The meter is equipped with 2 pulse outputs, which are fully isolated from the inside circuit:

- That generates pulses in proportion to the measured energy.
- The digital outputs are not short circuit protected.
- An external auxiliary voltage with overcurrent protective device is required, voltage range is 5-27VDC.
- The maximum input current shall be 27mA.
- Connected cables longer than 30 m must be shielded.
- Pulse output 1 is configurable.
- Pulse output 2 is non-configurable. It is fixed up with total kWh. The constant is 1000imp/kWh.

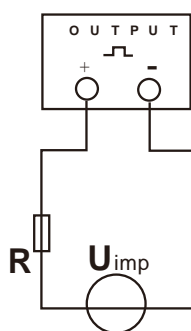
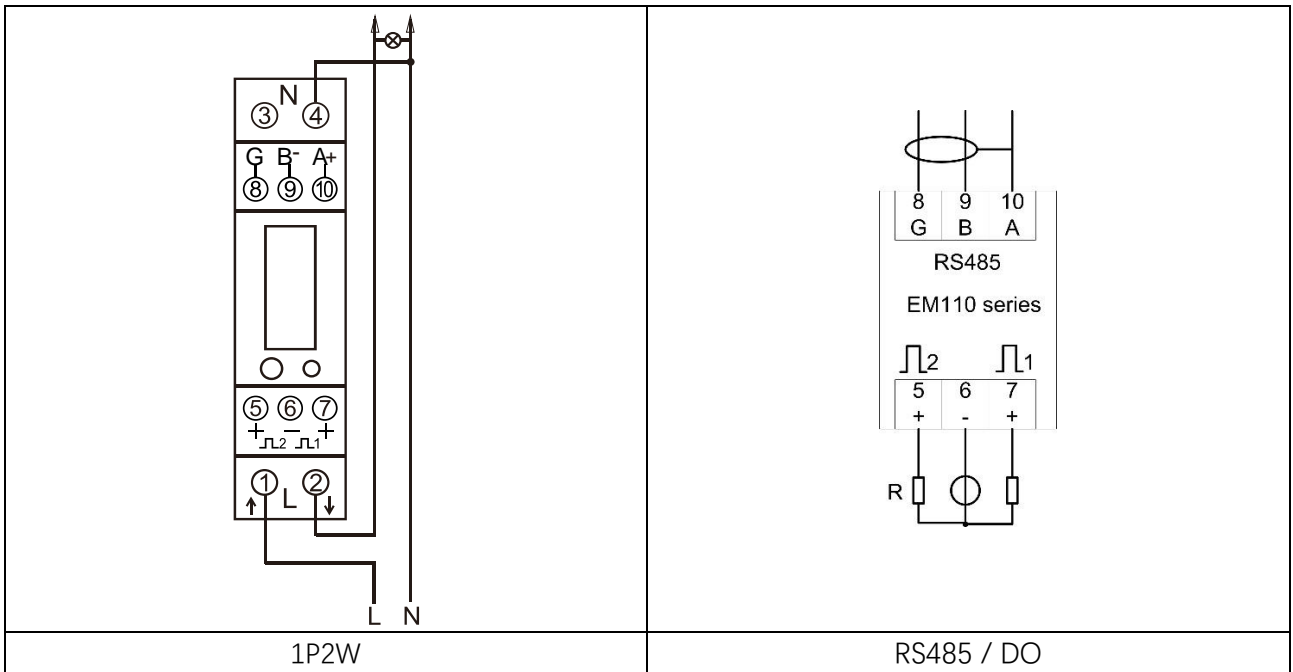

Fig.: Connection of digital outputs



Pulses output must be fed as shown in the wiring diagram. Scrupulously respect polarities and the connection mode.

# Examples of electrical connections



# Configuration and display

## Self-check after power on

When device is power on, the meter will initialize and do self-check:

<p>Full screen It will last for 3s</p>	<p>Software version It will last for 3s</p>







	<p>The software version is different according to the actual situation.</p>
	<p>After a short delay, the screen will display active energy measurements.</p>
	<p>Device could not be used if self-check failed.</p>



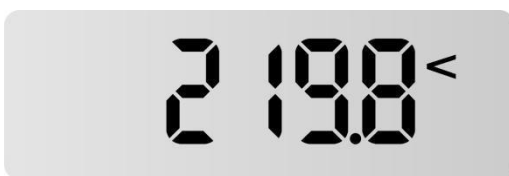

## Button functions

Buttons	Click	Press 3S
	<p>➤ Scroll the measurements</p>	<p>➤ Enter set-up mode</p>

## Overview of measured value displays

If the user wants to check other information, the scroll button on the front panel needs to be pressed:

1		Total active energy (kWh) Display format: 0000.00→9999.99→10000.0→99999.9→0000.00
1-1		Import active energy (kWh) Display format: 0000.00→9999.99→10000.0→99999.9→0000.00
1-2		Export active energy (kWh) Display format: 0000.00→9999.99→10000.0→99999.9→0000.00
2		Voltage (V)
3		Current (A)
4		Active power (W)
5		Frequency (F)

6		Power factor (PF)
7		Modbus Address (ID) Default: 001
8		Baud rate Default: 9600bps
9		Parity None/even/odd are optional Default: none

## Set-up Mode

The user need keep pressing the button for 3 seconds, the meter LCD will show “-SET-”.



The user can program the meter parameters by sending correct command via RS485 port.  
The protocol is Modbus RTU.

# Modbus Communication Protocol

## Input Registers, Function code 04

Address (Register)	Input Register Parameter				Modbus Protocol Start Address Hex	
	Description	Length (Byte)	Data Format	Units	Hi Byte	Lo Byte
30001	line to neutral volts	4	Float	V	00	00
30007	current	4	Float	A	00	06
30013	active power	4	Float	W	00	0C
30019	apparent power	4	Float	VA	00	12
30025	reactive power	4	Float	VAr	00	18
30031	power factor <sup>(1)</sup>	4	Float	None	00	1E
30071	Frequency of voltages	4	Float	Hz	00	46
30073	Total import active energy .	4	Float	kWh	00	48
30075	Total export active energy .	4	Float	kWh	00	4A
30077	Total import reactive energy .	4	Float	kVArh	00	4C
30079	Total export reactive energy .	4	Float	kVArh	00	4E
30085	Total system power demand <sup>(2)</sup>	4	Float	W	00	54
30087	Maximum total system power demand <sup>(2)</sup>	4	Float	W	00	56
30089	Import active power demand	4	Float	W	00	58
30091	Import active power max. demand	4	Float	W	00	5A
30093	Export active power demand	4	Float	W	00	5C
30095	Export active power max. demand	4	Float	W	00	5E
30259	current demand	4	Float	A	01	02
30265	Maximum current demand	4	Float	A	01	08
30343	Total active Energy <sup>(3)</sup>	4	Float	kWh	01	56
30345	Total reactive Energy <sup>(3)</sup>	4	Float	kVArh	01	58

Notes:

1. The power factor has its sign adjusted to indicate the direction of the current. Positive refers to forward current, negative refers to reverse current.
2. The power sum demand calculation is for import – export.
3. Total kWh/kVarh equals to Import + export.

## Holding Register, Function code 03/10

Address Register	Holding Register Parameter		Modbus Protocol Start Address Hex		Description	Mode
	Parameters	Format	Hi Byte	Lo Byte		
40003	Demand Period	Float	00	02	Write demand period: 0~60 minutes, Default 60. Range: 0~60, 0 means function closed Length: 4 bytes Data Format: Float	r/w
40013	Relay Pulse Width	Float	00	0C	Write relay on period in milliseconds: 60, 100 or 200, default 100ms. Length: 4 bytes	r/w
40019	Network Parity Stop	Float	00	12	Write the network port parity/stop bits for MODBUS Protocol, where: 0 = One stop bit and no parity. default. 1 = One stop bit and even parity. 2 = One stop bit and odd parity. 3 = Two stop bits and no parity. Requires a restart to become effective. Length: 4 bytes	r/w
40021	Modbus Address	Float	00	14	Ranges from 1 to 247. Default ID is 1. Length: 4 bytes	r/w
40029	Baud rate	Float	00	1C	0:2400bps 1:4800bps 2:9600bps(default) 5:1200bps Length: 4 bytes	r/w
40087	Pulse 1 output mode	Hex	00	56	0001: Import active energy 0002: Import + export active energy 0004: Export active energy, (default) 0005: Import reactive energy 0006: Import + export reactive energy 0008: Export reactive energy Length: 4 bytes	r/w
461457	Reset	Hex	F0	10	0000: Reset the Maximum demand Length: 2 bytes	wo
463745	Time of scroll display	BCD	F9	00	0-30s Default 0: does not display in turns	r/w



					Length: 2 bytes	
463761	Pulse 1 output	Hex	F9	10	0000:0.001kWh/imp(default) 0001:0.01kWh/imp 0002:0.1kWh/imp 0003:1kWh/imp Length: 2 bytes	r/w
464513	Serial number	Unsigned Int 32	FC	00	Serial number Length: 4 bytes Note: Only read	ro

## Dimensional drawings

All dimensions in mm.

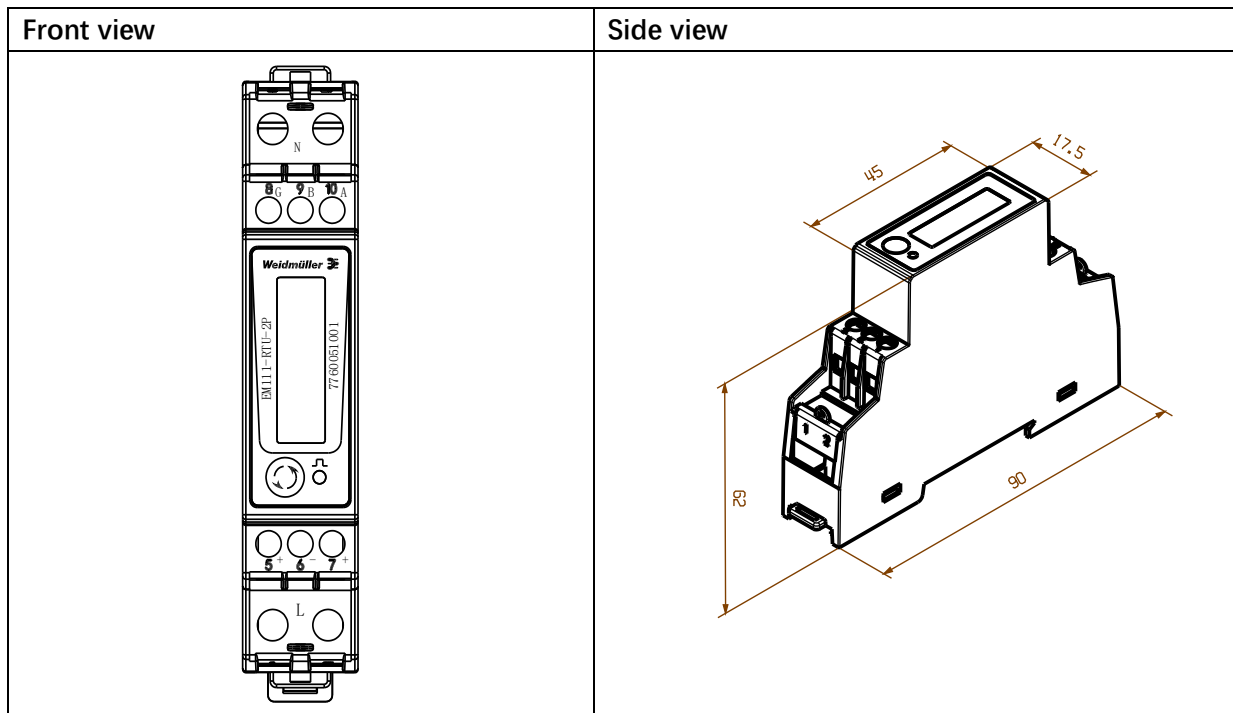

# Connecting example

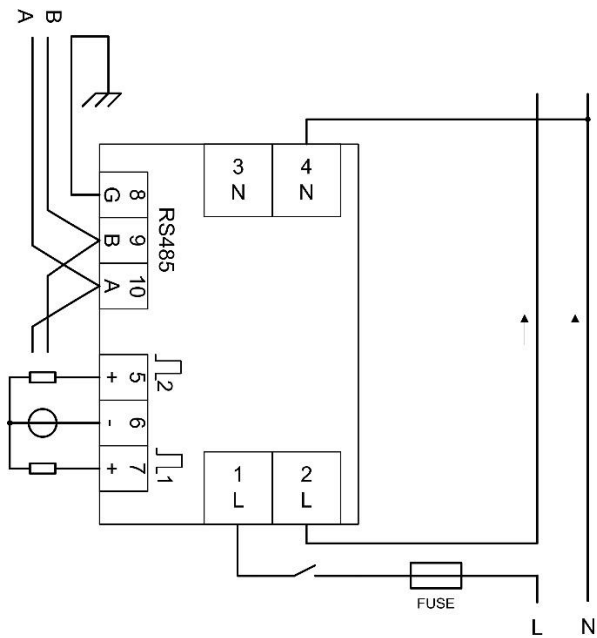

Fig.: Connecting example



The overcurrent protection device must be UL/IEC certified.